

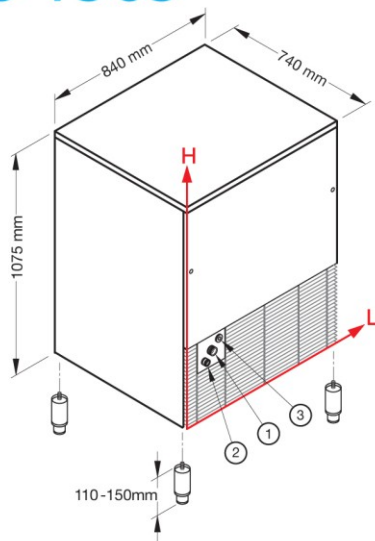

CB 1265·1565

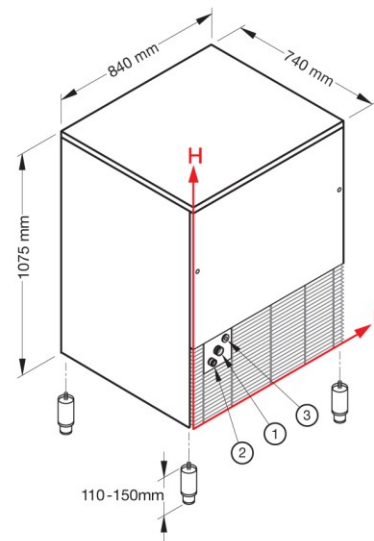

CB 1265



CB 1565

CONNECTIONS / CONNESSIONI	CB 1265			CB 1565		
	L	H	Ø	L	H	Ø
<input checked="" type="checkbox"/> Water inlet / Ingresso acqua	141	290	3/4"	141	290	3/4"
<input checked="" type="checkbox"/> Water outlet / Scarico acqua	79	245	24 mm	79	245	24 mm
<input checked="" type="checkbox"/> Electrical connection / Connessione elettrica	186	326	-	186	326	-

TECHNICAL INFORMATION / DATI TECNICI	CB 1265	CB 1565
Production in 24 h, till / Produzione in 24 h, sino a	130 kg	155 kg
Storage capacity / Capacità contenitore	65 kg ≈ 3830 □	65 kg ≈ 3830 □
Cooling system / Condensazione	A - W	A - W
Kind of cube / Tipo di cubetto	A-18g C-33g D-13g E-42g	A-18g C-33g D-13g E-42g
Refrigerant / Refrigerante	R404A	R404A
Standard voltage / Voltaggio standard	220-240 V ~ 50 Hz	220-240 V ~ 50 Hz
Electrical consumption / Consumo elettrico	1050 W	1400 W
Fuse / Fusibile	16 A	16 A
Water consumption (l/kg) / Consumo acqua (l/kg)	A 2,8 W 15,3	A 2,6 W 13
Sizes (WxDxH) / Dimensioni [LxPxH]	840x740x1075 mm	840x740x1075 mm
Sizes with packing (WxDxH) / Dimensioni con imballo [LxPxH]	880x785x1245 mm	880x785x1245 mm
Weight (net/gross) / Peso [netto/lordo]	113/133 kg	118/138 kg

Finishing 18/8 stainless steel, scotch brite / Finitura acciaio inox 18/8, scotch brite

INSTALLATION CONDITIONS / CONDIZIONI D'INSTALLAZIONE	Min / Max
Installation / Installazione	indoor / interna
Ambient temperature / Temperatura ambiente	+10 / +43 °C
Water temperature / Temperatura acqua	+3 / +32 °C
Voltage / Voltaggio	± 10%
Water inlet pressure / Pressione dell'acqua in ingresso	1bar (14psi) / 6bar (84psi)

CONDITIONS / CONDIZIONI	
Standard Cube / Cubetto standard	18g
Ambient temperature / Temperatura ambiente	+21°C
Water temperature / Temperatura acqua	+15°C
Electrical consumption at +43°C (standard voltage) / Consumo elettrico a +43°C (voltaggio standard)	



CB 1265·1565

Automatic ice cube maker - spray system.

Quality cubes: compact, cold and crystalline.

The ice produced drops into the ice collection bin. Particularly suitable for activities with large-scale ice demands in limited spans.

Produttori automatici di ghiaccio in cubetti - sistema a spruzzo.

Cubetti di qualità: compatti, freddi e cristallini.

Il ghiaccio prodotto cade nel contenitore di raccolta ghiaccio. Particolarmente adatti ai locali con forti necessità di ghiaccio fasce orarie.



CB 1265



CB 1565

